



WanXiang Solar



SOLAR MODULES WXS20S

Specifications

Cell Type	Mono-Silicon solar Cells
Cell Size	62.5mm×62.5mm
No. of cells and connections	36(6×6)
Dimension of module(mm)	443×424×28mm
Weight	2.5Kg

Electrical Characteristics

Model	WXS20S
Maximum power at STC(Pm)	20W
Open-circuit voltage(Voc)	21.96V
Short-circuit current(Isc)	1.22A
Voltage at Pmax(Vmp)	17.64V
Current at Pmax(Imp)	1.13A
Application	DC 12V system

(STC:Irradiance AM1.5, 1000W/m², 25°C)

Limits

Fuse rating	10A
Maximum system voltage	715VDC
Operating temperature	-40~+85°C

Temperature and Coefficients

NOCT	48°C±2°C
Temp coefficient of Voc	-(0.33±0.03)%/°C
Temp coefficient of Isc	(0.035±0.015)%/°C
Temp coefficient of power	-(0.5±0.05)%/°C

NOCT:Nominal Operation Cell Temperature

Output

Type of output terminal	Junction box
Cable	4mm ²
Cable lengths	500mm
Connector	Plug type

Mechanical Characteristics

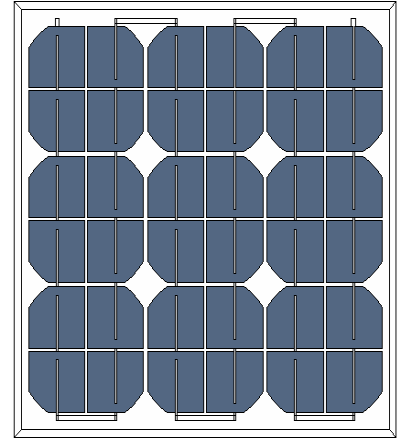
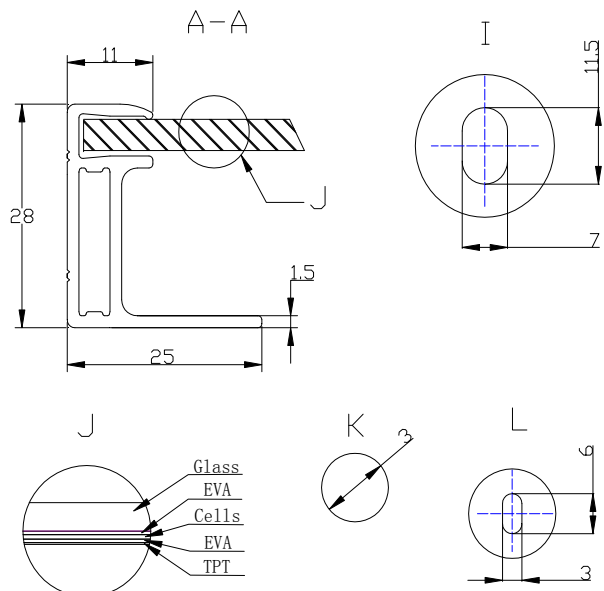
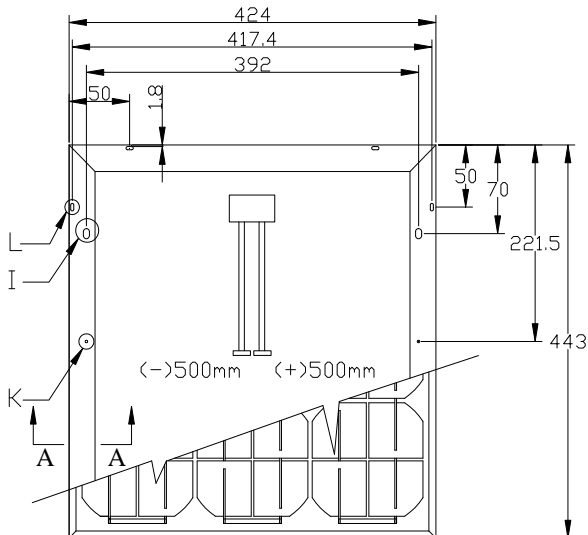

Characteristics Curve

